



Item # \_\_\_\_\_

# Model VCM-44A/1 Vertical Cutter/Mixer



Vertical Cutter/Mixer Model VCM-44A/1



Model VCM-44A/1



## Safety and Convenience Features

Berkel Model VCM44A/1 vertical cutter/mixer is a high-performance, high-volume and versatile machine that quickly and conveniently chops, blends, mixes and purees vegetables, fruits, cheeses and virtually any other product. The 47-quart capacity stainless steel, locking/tilt bowl rotates forward just past 90° to facilitate product removal and cleaning. The stainless steel cover includes a sight window that allows the operator to inspect the product during processing and opens to add ingredients. Attachments can be changed easily without tools. The bowl interlock prevents the cutter/mixer from running when the cover is raised. The unit's moisture resistant, push button controls and 99-minute digital timer permit continuous, jog and timed operation. A safety interlock shuts off power to the unit if the bowl cover is opened during machine operation. A variety of optional attachments are available adding to the versatility and productivity of this remarkable machine.

Approved By: \_\_\_\_\_  
Date \_\_\_\_\_

## Standard Features

- ▶ Heavy-duty, high-volume vertical cutter/mixer uses a high-speed, vortex cutter/mixer action to quickly and conveniently process virtually all types of food products in one easy operation – chop, blend, mix, puree and more
- ▶ High-grade, stainless steel knives and shaft rotate at 1750 RPM and are easily removed for cleaning; narrow, two-knife assembly and aluminum knead mix shaft are standard
- ▶ 1-speed, 7.5 HP, totally enclosed, and permanently lubricated, direct drive knife motor, thermally protected, external fan cooled
- ▶ Furnished in 208/60/3, 22.0 amp, AC, UL listed
- ▶ Bowl cover interlock prevents the cutter/mixer from running if cover is raised
- ▶ Highly reliable, moisture resistant, push button controls and 99-minute digital timer permits continuous, jog and timed operation; a safety interlock shuts off power to the unit if the bowl cover is opened during machine operation
- ▶ 47-quart (44.7 liter) capacity stainless steel, locking/tilt bowl rotates forward past 90° to facilitate product removal and cleaning
- ▶ Stainless steel cover with sight window permits viewing of the processing action and opens to add ingredients; attachments can be changed easily without tools
- ▶ Welded tubular steel base finish is Sky White, epoxy powder coat enamel for easy cleaning
- ▶ Attached 6-foot, flexible, 3-wire cord for grounded receptacle

## Accessories

- Wide Knives
- Angle Bent Knives
- Wide Wave Cut Knives
- Angle Bent Wave Cut Knives
- Stainless Steel Mixing Insert
- Small Quantity Stir Insert
- Owner's Video
- Strainer Basket (plastic)
- Grating Insert

Berkel Company • 4406 Technology Drive • South Bend, IN 46628-9700  
574-232-8222 • 800-348-0251 • FAX 888-888-2838 • www.berkel.com

**Berkel**

# Model VCM-44A/1

## Vertical Cutter/Mixer

Model No.	Bowl Capacity	Knife RPM	Product Dimensions		
			Width A	Depth B	Height C
VCM-44A/1	47 qts. (44.7 liters)	1750	32" (813 mm)	24" (610mm)	47" (1194 mm)

	Motor	Electrical	Weight	Box Dimensions		
				Width	Depth	Height
	1-speed 7.5 HP	208/60/3	Net 320 lbs. (145 kg.) Ship 490 lbs. (223 kg)	45" (1143mm)	37" (940 mm)	40" (1016 mm)

### Specifications

**Design:** Heavy-duty, high-volume vertical cutter/mixer uses a high-speed, vortex cutter/mixer action to quickly and conveniently process virtually all types of food products in one easy operation — chop, blend, mix, puree and more.

**Motor:** 1-speed, 7.5 HP, totally enclosed, permanently lubricated ball bearings, thermally protected, external fan cooled.

**Electrical:** Furnished in 208/60/3, 22 amp, AC, UL listed.

**Finish/construction:** Welded tubular steel base finish is Sky White, epoxy powder coat enamel for easy cleaning.

**Bowl:** The 47 quart (44.7 liter) capacity stainless steel bowl with a locking/tilt mechanism rotates forward 90° to facilitate product removal and cleaning. Attachments can be changed easily without tools.

**Bowl Cover:** The stainless steel cover with sight window permits viewing of the processing action and opens to add ingredients. An electromagnetic interlock prevents the cutter/mixer from running if cover is raised.

**Knives:** High-grade, stainless steel knives and shaft rotate at 1750 RPM and are easily removed for cleaning. The narrow two-knife assembly and aluminum knead mix shaft are standard.

**Switch:** Highly reliable, moisture resistant, push button controls and 99-minute digital timer permits continuous, jog or timed operation. A safety interlock shuts off power to the unit if the bowl cover is opened during machine operation.

**Cord and Plug:** Attached 6-foot, flexible, 3-wire cord for grounded receptacle.

**Warranty:** All parts, service and travel coverage for one year, excluding wear items.

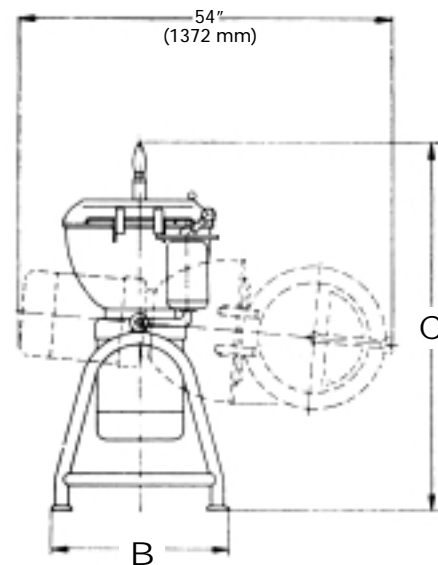
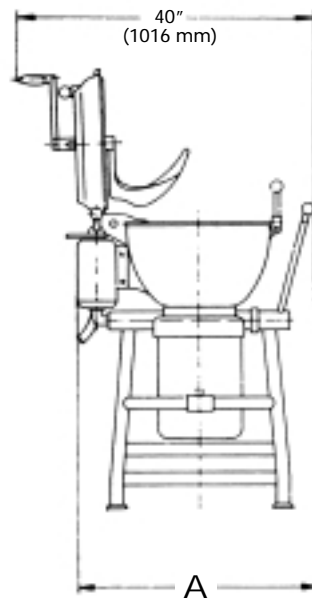

As we continually strive to improve our products, specifications are necessarily subject to change without notice.

Berkel Company • 4406 Technology Drive • South Bend, IN 46628-9700  
574-232-8222 • 800-348-0251 • FAX 888-888-2838 • www.berkel.com