



Item # _____

Model 919A Automatic Gravity Feed Slicer



Automatic Gravity Feed Slicer Model 919A



Model 919A



Safety and Convenience Features

Berkel Model 919A automatic gravity feed slicer features Berkel's time proven hollow ground stainless steel knife, built-in, single lever, dual-action sharpener and many safety features. The permanent, tapered guard covers the non-slicing portion of the knife even when the sharpener and center plate are removed. The gauge plate interlock prevents the product table from being removed unless it is in the full forward or home position and the gauge plate is closed. Removing the product table locks the gauge plate in the closed position. The center plate interlock prevents the slicer from operating if the center plate is removed. A built-in timer automatically shuts off the unit after 15 seconds of non-use. The unit is easy to clean and disassembles quickly without tools.

Accessories

- Stainless steel vegetable chute with pusher
- 4" Extension NSF legs (set of 4)
- Skewers with coring tool
- SURE-LOCK LIFT™
- Sharpening kit
- Slaw tray
- Receiving tray
- Juice cup
- Product fence

Approved By: _____
Date _____

Standard Features

- 2-speed, 1/2 HP, totally enclosed and permanently lubricated knife motor
- 2-speed, automatic carriage; low speed is 40 SPM, high speed is 60 SPM
- Furnished in 115/60/1, 5.5/4.5 amp, AC, ETL listed; also available in 1/3 HP, 230/60/1, 2.9 amp, AC, ETL listed
- Low 12/5 VDC circuitry for added operator protection
- Finish is stainless steel and sanitary burnished aluminum; unit disassembles quickly without tools for easy cleaning
- Nominal 12-1/2" (318 mm) diameter, hollow ground, hardened and polished forged stainless steel knife
- The carriage handles food up to 11" (280 mm) wide, by 6" (152 mm) high or 8" (203 mm) diameter
- Rear-mounted, stainless steel meat pusher extends over the entire length of the product table; a fence is provided to control the product on the table
- Precise slice adjustment to a thickness of 27/32" (21 mm)
- Ergonomic style handle for ease of use
- Built-in, top-mounted, two stone knife sharpener with single lever, dual-action system
- Permanent, tapered knife ring guard covers non-slicing portion of knife even when the sharpener and center plate are removed
- Center plate interlock prevents the slicer from running when center plate is removed
- No-Volt release prevents activation of the slicer in the event of power interruption; operator must restart the slicer
- Gauge plate interlock prevents removal of the product table until it is in the full forward or home position and the gauge plate is fully closed; once table is removed, gauge plate cannot be reopened
- Built-in timer automatically shuts the slicer off after 15 seconds of non-use
- Q-P-Q nickel plated transport slide rod with reservoir wick for reduced wear
- On/off, 3-position, moisture protected switch, with power light
- Attached 6-foot, flexible, 3-wire cord and plug for grounded receptacle

Options

- 1/3 HP, 230/60/1, 2.9 amp, AC, ETL listed

Berkel Company • 4406 Technology Drive • South Bend, IN 46628-9700
574-232-8222 • 800-348-0251 • FAX 888-888-2838 • www.berkel.com

**Berkel**

Model 919A

Automatic Gravity Feed Slicer

Model No.	Cutting Capacity	Slice Thickness	Knife Diameter	Slicing Speed	Product Dimensions		
					Width A	Depth B	Height C
919A	11" (280 mm) wide 6" (152 mm) high 8" (203 mm) dia.	to 27/32" (21 mm)	12-1/2" (318 mm)	low-40 SPM high-60 SPM	20" (508 mm)	29" (737 mm)	24" (610 mm)

Motor	Electrical	Weight	Box Dimensions		
			Width	Depth	Height
2-speed 1/2 HP	115/60/1	Net 114 lbs. (52 kg) Ship 160 lbs. (73 kg)	32" (813 mm)	30" (762 mm)	30" (762 mm)

Specifications

Motor: 2-speed, 1/2 HP, totally enclosed, permanently lubricated ball bearings, thermally protected.

Carriage: 2-speed, automatic carriage; low speed is 40 SPM, high speed is 60 SPM.

Electrical: Furnished in 115/60/1, 5.5/4.5 amp, AC, ETL listed. Also available in 1/3 HP, 230/60/1, 2.9 amp, AC, ETL listed. Low 12/5 VDC circuitry for added operator protection.

Finish/construction: All food contact areas are stainless steel including the pusher, gauge plate, product table, center plate and knife; sanitary burnished aluminum ring guard and one-piece base with non-slip feet. Slicer disassembles quickly without tools for easy cleaning.

Knife: Nominal 12-1/2" (318 mm) diameter, hollow ground, hardened and polished forged stainless steel.

Cutting Capacity: Carriage handles food up to 11" (280 mm) wide by 6" (152 mm) high or 8" (203 mm) diameter. Product fence is standard.

Slice Thickness: Precision gear system with eccentric gear to prevent backlash, provides infinite slice adjustment and consistent cuts of hard or soft foods from tissue thin to 27/32" (21 mm).

Full Gravity Feed: Full 45° angle feed requires less mechanical pressure. Equipped with stainless steel, rear-mounted pusher that covers the entire length of the product table to hold product and minimize waste. An optional screw-in weight is also available. Ergonomic style handle for ease of use. A fence is standard.

Knife Sharpener: Built-in, top-mounted, two stone, single lever, dual-action system for a lasting, razor-sharp edge. Unit is removable and submersible for easy cleaning.

Knife Ring Guard: Permanent, tapered guard covers non-slicing portion of knife edge even when the sharpener and center plate are removed.

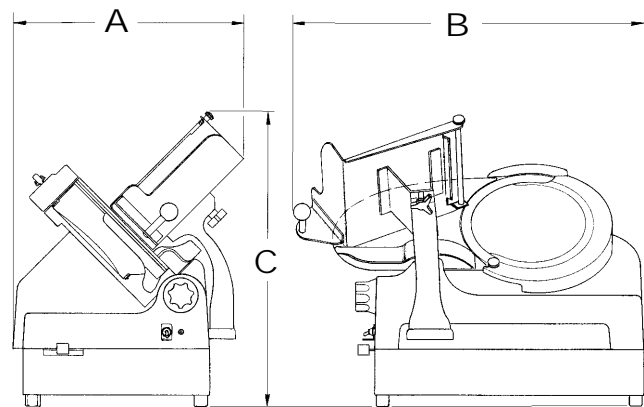

Center Plate Interlock: Deactivates the slicer when center plate is removed. Slicer will not run.

Gauge Plate Interlock: Prevents removal of table until gauge plate is closed and the product table is in the full forward or home position. Once product table is removed the gauge plate is locked and cannot be opened.

No-Volt Release: Prevents activation of the slicer in the event of power interruption. Operator must restart slicer.

15 Second Timer: Built-in timer automatically shuts off the slicer after 15 seconds of non-use.

On/Off Switch: Highly reliable, moisture resistant, 3-position switch with power light.

Q-P-Q Nickel Plated Transport Slide Rod with Reservoir Wick: E-nickel plated rod undergoes Q-P-Q impregnation increasing the lubricity of the stainless steel, reducing wear properties of the rod and bushings.

Cord and Plug: Attached 6-foot, flexible, 3-wire cord and plug for grounded receptacle.

Warranty: All parts, service and travel coverage for one year, excluding wear items.

As we continually strive to improve our products, specifications are necessarily subject to change without notice.

Berkel Company • 4406 Technology Drive • South Bend, IN 46628-9700
574-232-8222 • 800-348-0251 • FAX 888-888-2838 • www.berkel.com