



Item # _____

Model 909E Manual Gravity Feed Slicer



Manual Gravity Feed Slicer Model 909E



Model 909E



Safety and Convenience Features

Berkel Model 909E manual gravity feed slicer features Berkel's time proven hollow ground stainless steel knife, built-in dual action sharpener and a number of safety features. The permanent, tapered guard covers the non-slicing portion of the knife even when the sharpener and center plate are removed. The unit is easy to clean and disassembles quickly without tools.

Accessories

- Stainless steel vegetable chute with pusher
- Product fence
- Skewers with coring tool
- Sharpening kit
- Slaw tray
- Receiving tray
- Juice cup
- 4" Extension NSF legs (set of 4)

Standard Features

- 1-speed, 1/2 HP, totally enclosed and permanently lubricated knife motor, thermally protected
- Furnished in 115/60/1, 4.5 amp, AC, ETL listed; also available in 1/3 HP, 220/60/1, 2.4 amp, AC, ETL listed
- Low 12/5 VDC circuitry for added operator protection
- Finish is stainless steel and sanitary burnished aluminum; unit disassembles quickly without tools for easy cleaning
- Nominal 12-1/2" (318 mm) diameter, hollow ground, hardened and polished forged stainless steel knife
- The carriage handles food up to 11" (280 mm) wide, by 6" (152 mm) high or 8" (203 mm) diameter
- Rear-mounted, stainless steel meat pusher extends over the entire length of the product table
- Precise slice adjustment to a thickness of 27/32" (21 mm)
- Ergonomic style handle for ease of use
- Built-in, top-mounted, two stone knife sharpener with single lever, dual-action system
- Permanent, tapered knife ring guard covers non-slicing portion of knife even when the sharpener and center plate are removed
- Q-P-Q nickel-plated transport slide rod with reservoir wick for reduced wear
- On/Off, 3-position, moisture resistant switch with power light
- Attached 6-foot, flexible, 3-wire cord and plug for grounded receptacle
- No-Volt release prevents activation of the slicer in the event of a power interruption; operator must restart the slicer

Options

- 1/3 HP, 230/60/1, 2.9 amp, AC, ETL listed

Approved By: _____ Date _____

Berkel Company • 4406 Technology Drive • South Bend, IN 46628-9700
574-232-8222 • 800-348-0251 • FAX 888-888-2838 • www.berkel.com



Model 909E

Manual Gravity Feed Slicer

Model No.	Cutting Capacity	Slice Thickness	Knife Diameter	Product Dimensions		
				Width A	Depth B	Height C
909E	11" (280 mm) wide 6" (152 mm) high 8" (203 mm) dia.	to 27/32" (21 mm)	12-1/2" (318 mm)	20" (508 mm)	29" (737 mm)	21" (533 mm)

Motor	Electrical	Weight	Box Dimensions		
			Width	Depth	Height
1-speed 1/2 HP	115/60/1	Net 90 lbs. (41 kg) Ship 120 lbs. (55 kg)	32" (813 mm)	26" (660 mm)	27" (686 mm)

Specifications

Motor: 1-speed, 1/2 HP, totally enclosed, permanently lubricated ball bearings, thermally protected.

Electrical: Furnished in 115/60/1, 4.5 amp, AC, ETL listed. Also available in 1/3 HP, 220/60/1, 2.4 amp, AC, ETL listed. Low 12/5 VDC circuitry for added operator protection.

Finish/construction: All food contact areas are stainless steel including the pusher, gauge plate, product table, center plate and knife; sanitary burnished aluminum ring guard and one-piece base with non-slip feet. Slicer disassembles quickly without tools for easy cleaning.

Knife: Nominal 12-1/2" (318 mm) diameter, hollow ground, hardened and polished forged stainless steel.

Cutting Capacity: Carriage handles food up to 11" (280 mm) wide by 6" (152 mm) high or 8" (203 mm) diameter.

Slice Thickness: Precision gear system with eccentric gear to prevent backlash, provides infinite slice adjustment and consistent cuts of hard or soft foods from tissue thin to 27/32" (21 mm).

Full Gravity Feed: Full 45° angle feed requires less mechanical pressure. Equipped with rear-mounted, stainless steel meat pusher that runs the entire length of the product table to hold product and minimize waste. An optional screw-in weight is also available. Ergonomic style handle for ease of use.

Knife Sharpener: Built-in, top-mounted, two stone, single lever, dual-action system for a lasting, razor-sharp edge. Unit is removable and submersible for easy cleaning.

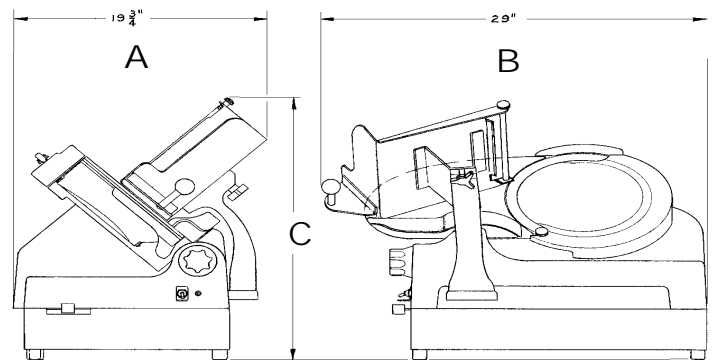

Knife Ring Guard: Permanent, tapered guard covers non-slicing portion of knife edge even when the sharpener and center plate are removed.

No-Volt Release: Prevents activation of the slicer in the event of a power interruption; operator must restart the slicer.

On/Off Switch: Highly reliable, moisture resistant, on/off switch and power light.

Q-P-Q Nickel Plated Transport Slide Rod with Reservoir Wick: E-nickel plated rod undergoes Q-P-Q impregnation increasing the lubricity of the stainless steel reducing wear properties of the rod and bushings.

Cord and Plug: Attached 6-foot, flexible, 3-wire cord and plug for grounded receptacle.

Warranty: All parts, service and travel coverage for one year, excluding wear items.

As we continually strive to improve our products, specifications are necessarily subject to change without notice.

Berkel Company • 4406 Technology Drive • South Bend, IN 46628-9700
574-232-8222 • 800-348-0251 • FAX 888-888-2838 • www.berkel.com