



Item # _____

Model 705 Tenderizer/Stir Fry Cutter

- 705 Tenderizer
- 705-S Stir Fry Cutter



Model 705



Safety and Convenience Features

Berkel Model 705 tenderizer produces a better product. The unit provides a smooth meat flow and uniform tenderizing pattern that cuts and knits the meat from both sides simultaneously. This thorough tenderizing process produces an appetizing product that seals in the juices when cooked. The clear Lexan safety cover facilitates the feed process while keeping the operator's hands at a safe distance from the tenderizing blades. An electromagnetic interlock cuts power to the unit when the cover is raised.

Model 705-S Stir Fry Cutter produces clean, uniform 3/8" or 1/2" thick strips of meat. The unit's stainless steel knives with positive product drive produce up to 13 consistently cut strips at a time. Both models are easy to clean and disassemble quickly without tools.

Standard Features

- Model 705 Tenderizer consists of 86 blades on two rollers providing 1,118 cutting edges; design cuts and knits the meat from both sides simultaneously for smooth meat flow and a uniform tenderizing pattern that tightly seals in juices when cooked
- Model 705-S Stir Fry Cutter produces clean, uniform strips of meat to a pre-set thickness of either 1/2" (13 mm) or 3/8" (10 mm) thick; up to 14 stainless steel knives cleanly cut up to 13 strips at a time
- 1-speed, 1/2 HP, totally enclosed and permanently lubricated knife motor
- Furnished in 115/60/1, 7.6 amp, AC, ETL listed
- Finish is corrosion resistant and sanitary burnished aluminum with clear Lexan safety cover; unit disassembles quickly without tools for easy cleaning
- Model 705 Tenderizer Basket assembly includes blades, rollers and strippers of heavy-duty stainless steel, with nylon spacers
- Model 705-S Stir Fry Cutter Basket assembly includes blades, spacers, traction drive and stripper of heavy-duty stainless steel
- The unit handles product up to 1-1/4" (32 mm) thick by 7-7/8" (200 mm) wide
- Direct gear drive transmission, resiliently coupled and enclosed with permanently lubricated gear box
- Safety cover electromagnetic interlock prevents the tenderizer from running when cover is raised
- On/off, rocker type switch
- Attached 6-foot, flexible, 3-wire cord and plug for grounded receptacle
- Model SFC Stir Fry Cutter Basket Assembly converts 705 and earlier model Berkel tenderizers to optional stir fry cutters

Accessories

- SFC Stir Fry Cutter Basket – 3/8" (10 mm)
- SFC Stir Fry Cutter Basket – 1/2" (13 mm)
- Leg Runners

Approved By: _____ Date _____

Berkel Company • 4406 Technology Drive • South Bend, IN 46628-9700
 574-232-8222 • 800-348-0251 • FAX 888-888-2838 • www.berkel.com



Tenderizer/Stir Fry Cutter Model 705



Model 705 Tenderizer/Stir Fry Cutter

Model No.	Product Capacity	705-S Slice Thickness	Output Speed	Product Dimensions		
				Width A	Depth B	Height C
705	1-1/4" (32 mm) thick 7-7/8" (200 mm) wide	1/2", 3/8" (13, 10 mm)	120 RPM	16-1/8" (410 mm)	13-5/8" (346 mm)	16-1/4" (413 mm)

Motor	Electrical	Weight	Box Dimensions		
			Width	Depth	Height
1-speed 1/2 HP	115/60/1	Net 62 lbs. (28 kg) Ship 70 lbs. (32 kg)	20-1/2" (521 mm)	19" (483 mm)	19" (483 mm)

Specifications

Models: Model 705 Tenderizer consists of 86 blades on two rollers providing 1,118 cutting edges; design cuts and knits the meat from both sides simultaneously for smooth meat flow and a uniform tenderizing pattern that tightly seals in juices when cooked.

Model 705-S Stir Fry Cutter produces clean, uniform strips of meat to a pre-set thickness of 1/2" (13 mm) or 3/8" (10 mm) thick. Stainless steel knives cleanly cut up to 13 strips at a time.

Model SFC Stir Fry Cutter Basket Assembly converts 705 and earlier model Berkel tenderizers to optional stir fry cutters.

Motor: 1-speed, 1/2 HP, totally enclosed, permanently lubricated ball bearings, thermally protected.

Electrical: Furnished in 115/60/1, 7.6 amp, AC, ETL listed.

Finish/construction: Finish is corrosion resistant and sanitary burnished aluminum with clear Lexan safety cover. The unit disassembles quickly without tools for easy cleaning.

Transmission: Direct gear drive transmission, resiliently coupled and enclosed with permanently lubricated gearbox.

Cutting Capacity: Model 705 and 705-S handle product up to 1-1/4" (32 mm) thick by 7-7/8" (200 mm) wide.

Tenderizer Group: Model 705 Tenderizer Basket assembly includes blades, rollers and strippers of heavy-duty stainless steel with nylon spacers.

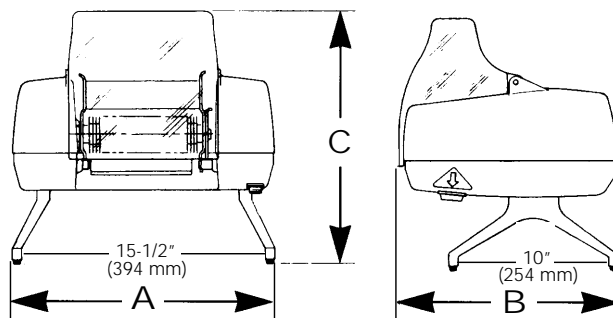

Stir Fry Cutter Group: Model 705-S Stir Fry Cutter Basket assembly includes blades, spacers, traction drive and stripper of heavy-duty stainless steel.

Safety Cover Interlock: Electromagnetic interlock deactivates the tenderizer/stir fry cutter when the safety cover is raised so the unit will not run.

On/Off Switch: Highly reliable, on/off, manual, rocker type switch.

Cord and Plug: Attached 6-foot, flexible, 3-wire cord and plug for grounded receptacle.

Warranty: All parts, service and travel coverage for one year, excluding wear items.

As we continually strive to improve our products, specifications are necessarily subject to change without notice.

Tenderizer/Stir Fry Cutter Model 705



Berkel Company • 4406 Technology Drive • South Bend, IN 46628-9700
574-232-8222 • 800-348-0251 • FAX 888-888-2838 • www.berkel.com