



Item # _____

Model 420A Vacuum Package Machine



Vacuum Package Machine Model 420A



Model 420A



Safety and Convenience Features

Berkel Model 420A is a reliable, high production floor model vacuum package machine designed to meet most high-volume foodservice portion control and product storage and food retail needs. The unit offers two spacious stainless steel chambers, powerful, high quality pump and four 17" seal bars that provide a high integrity double seal with electric cut-off. The 420A offers an anaerobic gas flush to maintain product color in the vacuum package, extend shelf live and/or to provide a pillow-pack seal to protect the product. Unit is simple to operate and maintain.

Standard Features

- ▶ Floor model with a stainless steel housing and double 27" (686 mm) x 24" (610 mm) x 8" (203 mm) chamber
- ▶ Four 17" (432 mm) seal bars provide high integrity double sealing with electric cut-off
- ▶ Powerful, high quality 63 m³/h Busch pump and vacuum dial gauge
- ▶ 1-speed, 3 HP motor, totally enclosed, permanently lubricated ball bearings, thermally protected
- ▶ Furnished in 220/60/3, 16 amp, AC, ETL listed
- ▶ Vacuum intervals of 1 to 99 seconds
- ▶ Gas flush for the addition of an anaerobic gas mixture and/or pillow-pack seal
- ▶ Simple to operate electronic, touch pad controls with nine storable programs
- ▶ Attached 6-foot, flexible, 3-wire cord for grounded receptacle

Accessories

- Air Assist
- Soft Air

Approved By: _____ Date _____

Berkel Company • 4406 Technology Drive • South Bend, IN 46628-9700
574-232-8222 • 800-348-0251 • FAX 888-888-2838 • www.berkel.com



Model 420A Vacuum Package Machine

Model No.	Chamber Size			Seal Bars	Seal Bar Length	Product Dimensions		
	Width	Depth	Height			Width A	Depth B	Height C
420A	27" (686 mm)	24" (610 mm)	8" (203 mm)	4	17" (432 mm)	52" (1321 mm)	31" (787 mm)	43" (1092 mm)

	Pump m ³ /h	Electrical	Weight	Box Dimensions		
				Width	Depth	Height
	63	220/60/3	Net 468 lbs. (213 kg) Ship 625 lbs (284 kg)	60" (1524 mm)	35" (889 mm)	46" (1168 mm)

Specifications

Finish/Construction: Floor model with stainless steel housing and two vacuum chambers.

Pump: Powerful, high quality, 63 m³/h Busch pump and vacuum dial gauge.

Electrical: Furnished in 220/60/3, 16 amp, AC, ETL listed.

Vacuum Chamber: Two, stainless steel 27" (686 mm) x 24" (610 mm) x 8" (203 mm) chamber. Vacuum intervals of 1 to 99 seconds.

Seal Bar(s): Four 17" (432 mm) seal bars provide high integrity double sealing with electric cut-off.

Gas Flush: Provides for the addition of an anaerobic gas mixture and/or pillow-pack seal.

Controls: Simple to operate electronic, touch pad controls with nine storable programs.

Motor: 1-speed, 3 HP, totally enclosed, permanently lubricated ball bearings, thermally protected.

Cord and Plug: Attached 6-foot, flexible, 3-wire cord for grounded receptacle.

Warranty: All parts, service and travel coverage for one year, excluding wear items.

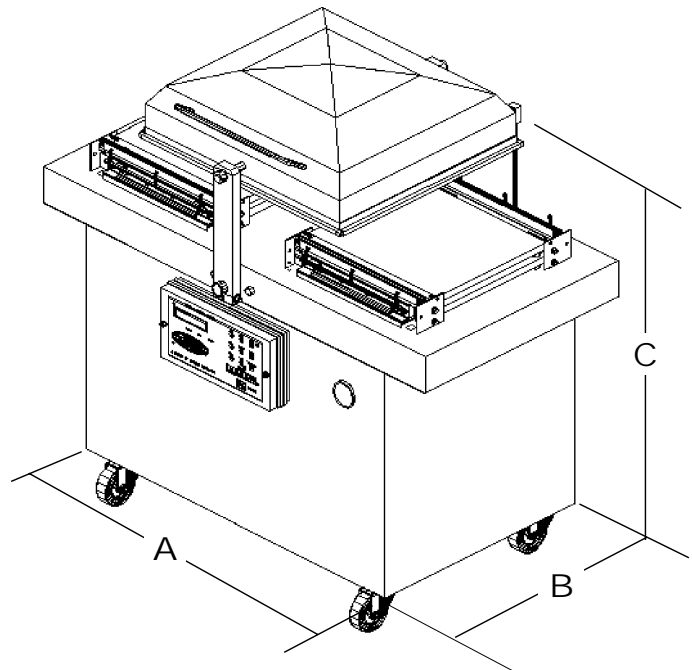

As we continually strive to improve our products, specifications are necessarily subject to change without notice.

Vacuum Package Machine Model 420A

Berkel Company • 4406 Technology Drive • South Bend, IN 46628-9700
574-232-8222 • 800-348-0251 • FAX 888-888-2838 • www.berkel.com

